

# WIRINGMATTERS

The Institution of Engineering and Technology

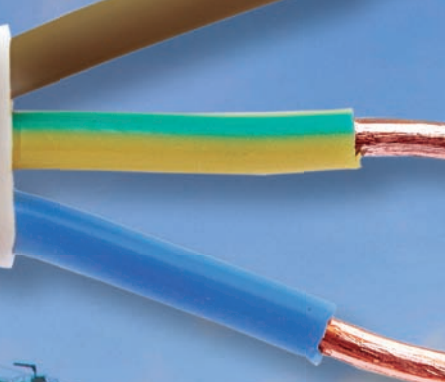

# CSCS

The construction skills certification scheme



**The CSCS and you**  
All you need to know about construction skills certification

**Electric vehicles**  
Requirements for charging vehicles via fixed installations

**Wiring regulations**  
BS 7671 and recognition of 'significant' people

**Multipole RCDs**  
How do you physically test three- and four-pole RCDs?



# Switched on?

Have you switched on to a new way of working with Newey & Eyre?

Order online up to 8pm for next day delivery or collect from 150 branches.

 [neweysonline.co.uk](https://www.neweysonline.co.uk)

DON'T DELAY, GO ONLINE AND SAVE TIME TODAY

 Newey & Eyre



An electric car charges up. [Reproduced with kind permission of future transport systems and Mitsubishi UK Ltd]

# Supplies to electric vehicles for charging purposes

## A brief overview

By Geoff Cronshaw

This is the second of two articles concerning the basic requirements for the connection of an electric vehicle to the fixed electrical installation.

In this article we take a closer look at the power requirements for charging electric vehicles, the types of electric vehicles, the existing standards relating to equipment for charging electric road vehicles, connections to the vehicles, and the requirements

for the electrical installation supporting the connection of an electric vehicle to the fixed electrical installation.

More and more electric vehicles and hybrid vehicles are on the market or being developed. The charging requirements vary considerably. Some electric vehicles are equipped with an on board charger and require a 230 V 3kW supply for up to 8 hours to ensure proper

charging of the electric vehicle traction battery, while others may require a smaller charge. Others require a three-phase supply. Vehicles may have a dedicated off-board charger designed to be used only with a specific type of electric vehicle, where the charger would provide a dc supply to the vehicle.

### BS EN 61851 series

At present BS EN 61851 Electric vehicle conductive charging system series of standards applies to equipment for charging electric road vehicles at standard a.c. supply voltages up to 690 V and at d.c. voltages up to 1000 V, when connected to the supply network.

BS EN 61851-1 2001 recognises a number of options for electric vehicle (EV) charging. One method is to connect the a.c. supply network (mains) to an on-board charger. The alternative method is to use an off-board charger for delivering direct current to the vehicle. In addition, the standard recognises that for charging in a short period of time special charging facilities operating at high power levels could be utilized.

BS EN 61851-1 2001 includes requirements for:

- EV charging modes,
- types of EV connection,
- functions provided in each mode of charging,
- serial data communication,
- protection against electric shock,
- protection against direct contact (basic protection),
- protection against indirect contact (fault protection),
- supplementary measures,
- provision for the traction battery,
- additional requirements,
- connection between the power supply and the EV,
- specific inlet, connector, plug and socket-outlet requirements (on vehicle) and the charging cable.

In addition, Part 1 includes a normative Annex giving the Charging cable assembly requirements and three informative Annexes giving details for a PWM control pilot circuit, control pilot circuit and coding tables for power indicator.

BS EN 61851-21: 2002 appears to supplement Part 1 and includes requirements for: electrical safety (earthing connection and electric vehicle continuity and detection of the electrical continuity of the protective conductor), electrical characteristics of the vehicle, electromagnetic compatibility, functional requirements (includes requirements for cable housing in the electric vehicle), electric vehicle inlet or plug requirements, and marking and instructions.

BS EN 61851-22: 2002 appears to supplement Part 1 and includes requirements for electric vehicle charging stations. However, the standard does not cover box type assemblies with socket-outlets, installed for the purpose of delivering energy to the vehicle, which have no charging control functions.

BS EN 61851-22 2002 includes requirements for functional and constructional requirements for the charging station - such as the minimum degree of IP protection for the charging station, the means of storage for the cable assembly, metering requirements, etc. Also, Electrical safety is covered including protection against indirect contact (fault protection), such as detection of the electrical continuity of the protective conductor. Finally a wide range of testing requirements is included.

Therefore, the requirements for electric vehicle charge points appear to be reasonably well catered for by BS EN 61851 series of standards. This article attempts to clarify the requirements for the electrical installation supporting the connection



**Electric vehicle. [Reproduced with kind permission of future transport systems and Mitsubishi UK Ltd]**

of an electrical vehicle to the fixed electrical installation.

### IEE Wiring Regulations (BS 7671:2008)

The IEE Wiring Regulations (BS 7671:2008) is the national standard for electrical installations in the UK up to 1000V a.c. and 1500V d.c.

BS 7671:2008 does not include a specific section giving requirements for the connection of an electric vehicle to the fixed electrical installation.

However, many of the requirements (such as: circuit design, RCD protection, measures of protection against electric shock, IP rating of equipment, impact protection against mechanical damage, isolation and switching, etc.) for the electrical installation associated with the power supply for the charging of an electric vehicle are covered in the general rules of BS 7671:2008; examples of the general rules are given below. It is important to point out that systems for the distribution

of electricity to the public are outside the scope of BS 7671, therefore, these requirements apply to private supplies such as those from dwellings and private commercial and industrial establishments, when charging the vehicle at home and at work.

### Circuit design

A circuit intended to supply an electric vehicle must fit for purpose and suitable for the load. It should be correctly designed in accordance with BS 7671:2008. Chapter 43 deals with protection

against overcurrent and also thermal constraints, Chapter 41 deals with protection against electric shock and gives the disconnection times that must be met whilst Section 525 deals with voltage drop. Appendix 4 gives current carrying capacity and voltage drop for cables. All these areas need to be taken into account when determining the cable size for a particular circuit.

### RCD protection

Regulation 411.3.3 requires



Wiring Matters is produced by IET Services Limited, a subsidiary of The Institution of Engineering and Technology (IET), for the IET. Michael Faraday House, Six Hills Way, Stevenage, Herts, SG1 2AY, United Kingdom Tel: +44 (0)1438 313311 Fax: +44 (0)1438 313465

Electrical excellence

**Advertising Sales** D Smith +44 (0)1438 767224 daniellesmith@theiet.org | **Editor** G D Cronshaw +44 (0)1438 767384 gcronshaw@theiet.org | **Contributing Editors** M Coles, J Elliott, P Bicheno | **Design** John Rooney, Jon Bonny, Dan Shadrake. IEE Wiring Matters is a quarterly publication from the Institution of Engineering and Technology (IET). The IET is not as a body responsible for the opinions expressed.

©2010: The Institution of Engineering and Technology. All rights reserved. No part of this publication may be reproduced, stored in a retrieval system, or transmitted in any form or by any means without the permission in writing of the publisher. Copying of articles is not permitted except for personal and internal use. Multiple copying of the content of this publication without permission is always illegal. Web-offset printing by Wyndeham Heron, The Bentall Complex, Colchester Road, Heybridge, Maldon, Essex, UK

**Co-operating Organisations** The Institution of Engineering & Technology acknowledges the contribution made by the following organisations in the preparation of this publication: British Electrotechnical & Allied Manufacturers Association Ltd – P D Galbraith, M H Mullins | Department for Communities and Local Government – I Drummond | Electrical Contractors Association – D Locke, S Burchell | City & Guilds of London Institute – H R Lovegrove | Electrical Contractors Association of Scotland SELECT – N McGuinness | Health & Safety Executive – K Morton | Electrical Safety Council | ERA Technology Limited – M Coates, A Finney | Consultant - M. Al-Rufaie | Dept of Health - C Holme | British Cables Association – C Reed | Scottish Building Standards Agency | Department for Business, Enterprise and Regulatory Reform | GAMBICA – M Hadley, A. Sedhev | Lighting Association – L Barling  
ISSN 1749-978-X

PASSED

# Megger



## In a CLASS of its own

**New** PAT300 series portable appliance testers raise the standard for manual and automatic PAT testing

- Easy one button operation
- A full range of PAT tests with an option of flash testing
- 230 V and 110 V operation and testing
- Plug-in RCD testing

To see how the bar has been raised  
just call 01304 502101

The word 'Megger' is a registered trademark

# Megger

WWW.MEGGER.COM

Megger Limited  
Archcliffe Road Dover CT17 9EN UK  
T +44 (0) 1304 502 101  
F +44 (0) 1304 207 342  
E [uksales@megger.com](mailto:uksales@megger.com)

that an RCD be used as additional protection for socket-outlets with a rated current not exceeding 20A which are for use by ordinary persons and are intended for general use. Regulation 415.1 requires that an RCD be used as additional protection for mobile equipment with a rated current not exceeding 32A for use outdoors. As indicated in the Regulations, the RCD has then to have a rated residual operating current not exceeding 30 mA and an operating time not exceeding 40 ms at a residual current of  $5 I_{\Delta n}$ . This requirement is met by general type devices complying with BS EN 61008 or BS EN 61009 (or BS 4293).

#### Protection against electric shock

There are four protective measures generally permitted by BS 7671:2008, given in Regulation 410.3.3: (i) Automatic disconnection of supply (Section 411) (ii) Double or reinforced insulation (Section 412) (iii) Electrical separation for the supply to one item of current-using equipment (Section 413) (iv) Extra-low voltage (SELV and PELV) (Section 414).

A note at the end of this Regulation acknowledges that, in electrical installations, the most commonly used protective measure is automatic disconnection of supply.

#### IP rating of equipment (External influences, presence of water (AD) or high humidity) (AB)

Regulation 522.3 requires that any wiring system or equipment selected and installed must be suitable for its location and able to operate satisfactorily without deterioration during its working life. The presence of water can occur in several ways, e.g. rain, splashing, steam/humidity, condensation and at each location where it is expected to be present its effects must be considered. Suitable protec-

tion must be provided, both during construction and for the completed installation. The IP classification code, BS EN 60529:2004, describes a system for classifying the degrees of protection by the enclosures of electrical equipment.

#### Impact protection against mechanical damage

Regulation 512.2 requires equipment to be of a design appropriate to the situation in which it is to be used. The effect of environmental conditions and general characteristics around an installation should always be assessed to enable suitable electrical equipment to be specified. All electrical equipment selected must be suitable for its location, use and method of installation. The IK classification standard BS EN 62262 describes a system for classifying the degrees of protection provided by enclosures for electrical equipment against external mechanical impacts. The letters IK are followed by two numerals which identify a specific impact energy.

#### Isolation and switching.

Chapter 53 recognises four distinct types of isolation and switching operation:

- (i) isolation
- (ii) switching off for mechanical maintenance
- (iii) emergency switching
- (iv) functional switching.

Some key regulations which must be considered include:

537.2.1.1 Every circuit shall be capable of being isolated from each of the live supply conductors. In a TN-S or TN-C-S system, it is not necessary to isolate or switch the neutral conductor where it is regarded as being reliably connected to Earth by a suitably low impedance.

Provision may be made for isolation of a group of circuits by a common means, if the service conditions allow this. 537.3.1.1 Means of switching off for mechanical maintenance shall be provided where



Electric vehicle. [Reproduced with kind permission of future transport systems Mitsubishi UK Ltd.]

mechanical maintenance may involve risk of physical injury.

537.3.1.2 Suitable means shall be provided to prevent electrically powered equipment from becoming unintentionally reactivated during mechanical maintenance, unless the means of switching off is continuously under the control of any person performing such maintenance.

537.3.2.3 A device for switching off for mechanical maintenance shall be designed and/or installed so as to prevent inadvertent or unintentional switching on.

537.3.2.4 A device for switching off for mechanical maintenance shall be so placed and durably marked so as to be readily identifiable and convenient for the intended use.

537.4.1.1 Means shall be provided for emergency switching of any part of an installation where it may be necessary to control the supply to remove an unexpected danger.

#### Socket-outlets

Socket outlets must be fit for purpose. They must be suitable for the load, and for the external influences such as protection against mechanical damage

and ingress of water. Section 553 deals with accessories such as plugs and socket outlets. However, Annex D of BS EN 61851-1 2001 (charging electric vehicles) recommends an industrial type socket-outlet to IEC 60309-2 which is a similar requirement to caravan sites in BS 7671 and would be suitable for non domestic installations in the UK. This is because Regulation 553.1.4 requires shuttered type socket outlets for household and similar.

#### ESQCR - Electricity Safety, Quality and Continuity Regulations 2002 (as amended).

#### Precautions to prevent the electric vehicle supplying the fixed installation.

There are mandatory requirements concerning the parallel connection of generators with the supply network, and the permission of the distributor must be obtained before a connection is made. Persons involved in this work are recommended to consult The Electricity Safety, Quality and Continuity Regulations 2002 (as amended). Section 551 of BS 7671:2008 gives requirements for the installation of generators.

It may be worth consulting the engineering recommendations

of the ENA. G83/1 published by the Energy Networks Association gives recommendations for the connection of small-scale embedded generators (Up to 16A per phase) in parallel with public low-voltage distribution networks. For larger generating plant Engineering Recommendations G59/1 also published by the Energy Networks Association gives recommendations for the connection of embedded generating plant to the public electricity supplier's distribution systems.

### Protective multiple earthing.

The Electricity Safety, Quality and Continuity Regulations 2002 (as amended) permit the distributor to combine neutral and protective functions in a single conductor provided that, in addition to the neutral to Earth connection at the supply transformer, there are one or more other connections with Earth.

The supply neutral may then be used to connect circuit protective conductors of the customer's installation with Earth if the customer's installation meets the requirements of BS 7671. This protective multiple earthing (PME) has been almost universally adopted by distributors in the UK as an effective and reliable method of providing their customers with an earth connection. Such a supply system is described in BS 7671 as TN-C-S.

Whilst a protective multiple earthing terminal provides an effective and reliable facility for the majority of installations, under certain supply system fault conditions (external to the installation) a potential can develop between the conductive parts connected to the PME earth terminal and the general mass of Earth. The potential difference between true Earth and the PME earth terminal is of importance when:

i.) body contact resistance is low (little clothing, damp/wet

conditions), and/or ii.) there is relatively good contact with true Earth.

Contact with Earth is always possible outside a building and, if exposed-conductive parts and/or extraneous-conductive-parts connected to the PME earth terminal are accessible outside the building, people may be subjected to a voltage difference appearing between these parts and Earth.

For this reason Regulation 9(4) of the The Electricity Safety, Quality and Continuity Regulations 2002 (as amended). does not allow a combined neutral and protective conductor to be connected to any metalwork in a caravan or boat.

It is not clear at this stage the effect of the Electricity Safety, Quality and Continuity Regulations on supplies to electric vehicles; however, it seems reasonable to assume the same requirements would apply to a vehicle as a caravan. If this was the case one option would be to convert the PME system to a TT system at the charge point for the vehicle. Persons involved in this work are advised to seek advice from HSE.

### Conclusion

This article gives a brief overview of the requirements of BS 7671:2008 for the electrical installation supporting the connection of an electrical vehicle to the fixed electrical installation.

### For further information refer to:

- BS 7671:2008, Requirements for electrical installations
- Engineering Recommendations G83/1 and G59/1 published by the Energy Networks Association
- The Electricity Safety, Quality and Continuity Regulations 2002 (as amended). published by the Department of Energy and Climate Change.
- BS EN 61851 series

*Special thanks to Future transport systems and EDF Energy.*

Which label says...  
...MORE ABOUT YOU?

DISTRIBUTION BOARD  
A/DB5/1

1L1 7L1  
1L2 7L2  
1L3 7L3  
2L1 8L1  
2L2 8L2  
2L3 8L3  
3L1 9L1  
3L2 9L2  
3L3 9L3  
4L1 10L1  
4L2 10L2  
4L3 10L3  
5L1 11L1  
5L2 11L2  
5L3 11L3  
6L1 12L1  
6L2 12L2  
6L3 12L3

A/DB5/1

MAIN SWITCH

PRICES START FROM ONLY £59.99 EX VAT

ROTATE PRINT FUNCTION PERFECT FOR CABLE AND PIPE LABELS

## How many times have you been let down by previous labelling?

A Brother P-touch label printer comes pre-loaded with electrical symbols, a back-lit display and produces durable labels, which leave a lasting impression of the true professional you really are. Ideal for all jobs from cable flagging and pipe identification to identifying electrical components.



Contact your usual electrical wholesaler or visit [www.brother.co.uk/electrician](http://www.brother.co.uk/electrician)

All Brother label printers come with a 3 year warranty upon registration.

**PT-7600VP**  
Includes carry case and mains adaptor

# Construction Skills Certification Scheme

by Paul Bicheno

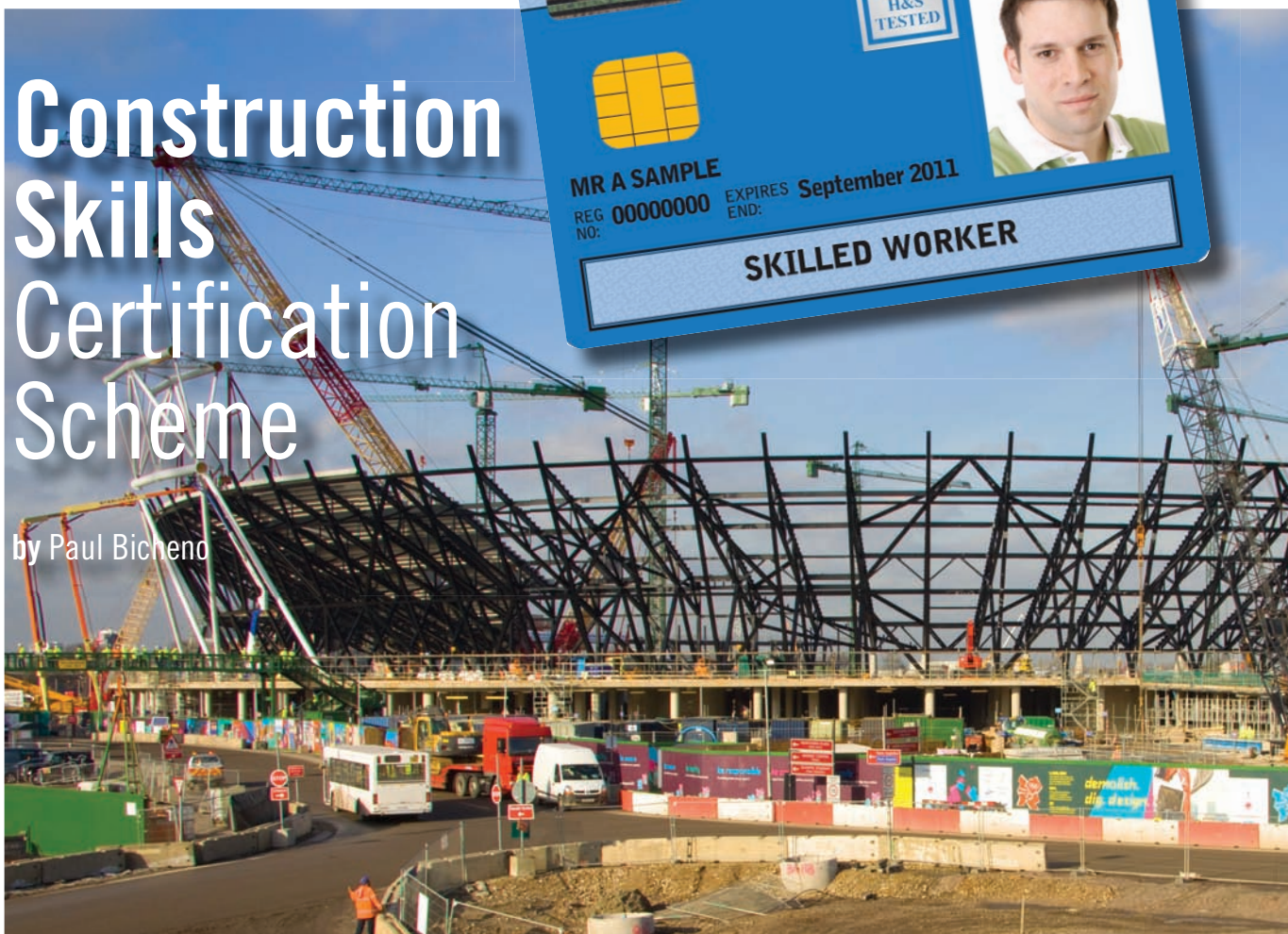

The IET receives queries relating to the Construction Skills Certification Scheme (CSCS). These queries range from tradesmen who want to work in the construction sector to members of professional bodies such as the IET whose job function may on occasion require their presence on construction sites. This article will briefly look at various aspects of the scheme including the types of registration, affiliated schemes and the electrotechnical scheme.

## What is the CSCS?

The scheme is essentially a competence card scheme for the construction sector. The objective is to improve the level of skills and competency and awareness of health and safety

risks which can exist within the construction sector by making sure that personnel have the appropriate recognised level of competence for a particular job function. The health and safety aspect is important because an individual needs to be aware of the risks to themselves and to others.

The scheme recognises a range of occupation types including trades, technical, supervisory and management with an individual being issued with an identification card showing who they are, their job function and their relevant qualifications. The cards are valid for a particular period, typically one, three or five years. Most major trade associations, professional insti-

tutions, clients and contractors support the scheme as it provides an easy way for construction workers, supervisors and managers to offer a degree of proof of their competence in a consistent manner. The CSCS card is required for proof of competence from a number of organisations from the industry as well as employers, clients and Government.

The CSCS is managed by a board including representatives from across the industry (see further information). The scheme itself is administered under licence by 'ConstructionSkills' who are the Sector Skills Council for the construction industry. This licence has just been renewed by the Government Business, Innovation and

Skills Secretary Lord Mandelson.

## Levels of card

There are a number of levels of card each of which has a particular identifying colour. Those achieving the normal vocational qualification route via NVQs/SVQs will be given a gold card. Other colours of card can be given to trainees, experienced workers working towards the formal vocational qualifications, those with industry accreditation and professional membership. There is even a visitor card. The individual must also pass the ConstructionSkills Health and Safety test that varies depending on the level of card. The levels of card are summarized in Table 1.



**Table 1 – Summary of Levels of CSCS card****CSCS 'SmartCard'**

From January 2010, 'Smart-Cards' will be issued to replace the existing format of CSCS cards, however current cards will still be valid until their expiry date. The new card is similar to a chip and pin type card where the related information about an individual is stored electronically and will be read by dedicated SmartCard hand held or PC based readers. This type of card will make it harder to produce counterfeit cards as they will be easily detected via the card readers because the details and identity of an individual can be checked automatically at point of entry every time rather than via a traditional manual query to the CSCS administration.

More data can be stored electronically for use in applications like attendance monitoring, occupational health restrictions and cashless vending. Updating of the data will be easier if someone needs to amend personal details or record additional training that has been completed.

**Affiliated and amalgamated schemes**

There are a number of affiliated or amalgamated schemes covering many specific occupations.

These schemes are based on the same standards as CSCS and require the holder to gain the appropriate vocational qualification and pass the Health and Safety test. These schemes are summarized in Table 2 – CSCS affiliated and amalgamated schemes.

Level	Colour	Occupation
Trainee / Graduate	Red	<b>This card is for;</b> <ul style="list-style-type: none"> <li>■ craft trainees working towards an appropriate vocational qualification</li> <li>■ trainees in technical, supervisory and management occupations registered on a construction related qualification in a further/higher establishment</li> <li>■ graduates with a recognised construction related qualification</li> </ul>
Construction Site Operative	Green	<b>This card is for</b> persons who would have occupations with basic skills e.g. Labourer.
Experienced Worker	Blue	<b>This card is for;</b> <ul style="list-style-type: none"> <li>■ persons that are workers who have on-the-job experience but have not been accredited. They would be looking to gain the appropriate qualification</li> <li>■ persons that are technicians, supervisors or managers who have on-the-job experience and whose occupation has industry accreditation or registering to gain the appropriate vocational qualification</li> </ul>
Skilled Worker	Blue	This card is for a skilled person who has achieved the appropriate vocational qualification or has completed an employer sponsored apprenticeship and completed a City and Guilds craft certificate.
Advanced Craft / Supervisory	Gold	<b>This card is for;</b> <ul style="list-style-type: none"> <li>■ persons that have a higher level of vocational qualification or has completed an indentured apprenticeship or has completed an employer sponsored apprenticeship and completed a City and Guilds advanced craft certificate</li> <li>■ persons who are in supervisor occupations and have a higher level of vocational qualification.</li> </ul>
Management	Platinum	This card has been withdrawn from the scheme on 1st January 2010. (applications are now for a Black card)
Management	Black	This is for managerial occupations and requires a high level of vocational qualification.
Professionally Qualified Person	Yellow	This is for non-site based professionals who would have relevant responsibilities such as Consultants, Client Architects and Surveyors.
Regular Visitor	Yellow	This is for people who do not have any construction specific skills but are regular visitors to a site. They will still need to pass the H&S test.
Construction Related Occupation	White	This is for construction related occupations that are not covered by the other card categories.
<b>Note: Some routes to gaining a card enabled an applicant to specifically use their experience as evidence known as 'industry accreditation'; however the majority of these routes are now closed.</b>		

Scheme Name	Occupation
<b>Assuring Competence in Engineering Construction (ACE)</b>	UK Engineering construction workers
<b>Certificate of Competence of Demolition Operatives (CCDO)</b>	Demolition operatives
<b>Construction Industry Scaffolders Record Scheme (CISRS)</b>	Scaffolders
<b>Construction Plant Competence Scheme (CPCS)</b>	Plant operators
<b>Construction Skills Register (CSR)</b>	The Northern Ireland equivalent to CSCS
<b>Electrotechnical Certification Scheme (ECS)</b>	various electrotechnical e.g. Installation Electrician, Building Controls Engineer
<b>Energy and Utility Skills Register (EUSR)</b>	Utility industry scheme including, Electricity, gas and water industry workers
<b>Join Industry Board for Plumbing and Mechanical Services (JIB-PMES)</b>	Plumbers (in England and Wales)
<b>Engineering Services Skillcard (SKILLcard)</b>	Heating, ventilating, air conditioning and refrigeration operatives
<b>Scottish and Northern Irish Joint Industry Board (SNIJIB)</b>	Plumbers (in Scotland and Northern Ireland)

**Table 2 – CSCS affiliated and amalgamated schemes**

### Electrotechnical certification scheme

One of the affiliated schemes is the Electrotechnical Certification Scheme (ECS). This is recognised by industry as the electrotechnical equivalent to the CSCS. The ECS is administered by the Joint Industry Board (England, Wales and Northern Ireland) and the Scottish Joint Industry Board (Scotland), the Electrical Contractors Association and SELECT. The Scheme enables all occupational levels of electrotechnical personnel to have their own card e.g. trainees to managers. Occupations are included for the following

areas;

- Electrical, Electronic and Management
- Datacomms
- Emergency and Security systems
- Fire Detection and Alarm systems

As an example, to be eligible for an ECS Installation Electrician card, applicants must meet the following criteria:

- have successfully completed an Approved Apprenticeship – or –
- hold the City and Guilds 2360 Part One and Two, or City and Guilds 2351 or City and



Guilds 2330 Levels 2 and 3 or Approved Equivalent – plus –

- NVQ Level 3 in Installation and Commissioning – and –
- hold a current (up-to-date) Health & Safety Certificate or recognized H&S qualification – and –
- hold a formal BS 7671 qualification in the current edition of the wiring regulations (currently BS 7671: 2008, 17th Edition)

### Members of Professional Institutions

As already highlighted, the Professionally Qualified Person

card is for individuals who are members of an approved institution (see further information for a link to a list). The individual's competence would be assessed against the relevant institutions requirements.

As a Gold or Platinum card holder of the Electrotechnical Scheme, the JIB is working in collaboration with the IET to enable an individual to gain membership and pursue their professional development with the aim of raising the level of professionalism. From the 1st April the PQP card criteria will be changing.

Members of the listed

# Friendlies in the World Cup?

Yes, if you're with ELECSA!

ELECSA are giving away **HDD Recorders**, **Xbox 360s** and **personalised England shirts**. For your chance to win these great prizes and to claim your **FREE** gift, go online now and take part in our penalty shoot out competition.

[www.elecsa.co.uk/gameon](http://www.elecsa.co.uk/gameon)

**Contractors on the ELECSA team benefit from:**

- ✓ Friendly and supportive assessors
- ✓ Free technical advice and support
- ✓ Customer warranties available at no cost to you, the contractor
- ✓ Straightforward and low cost job notification system
- ✓ Flexible monthly direct debit payment option available

Terms and Conditions apply.  
Full details available online.



IT'S GAME ON!

**ELECSA**  
Part of the ECA Group

**FREE**  
WORLD CUP GIFT

**IET**  
Electrical excellence

## In-Company electrical training

City &  
Guilds

Why not run courses on your premises, reducing your staff time away from the workplace as well as staff accommodation and travel costs? All of our public electrical training courses can be tailored to meet your requirements and provided in-house, making it convenient for you and your staff.

### New for 2010

- 1 day course in Periodic Reporting of Commercial and Industrial Electrical Installations
- 1 day course in Periodic Reporting of Domestic Installations

Both have been designed to assist electrically skilled personnel who require guidance in completing the periodic inspection report.

### Don't delay!

Are you a qualified supervisor? Are your qualifications updated to the 17th Edition?  
Do you need to comply with the Electrotechnical Assessment Specification (EAS)?

The IET provides two 17th Edition training courses & exams:

- 17th Edition workshop (C&G 2382-20)
- 17th Edition Certificate in the Requirements for Electrical Installations (C&G 2382-10)

To discuss your training requirements with one of our short course experts,  
please call **01438 767289** or email [coursesreg@theiet.org](mailto:coursesreg@theiet.org)

[www.theiet.org/courses-wm](http://www.theiet.org/courses-wm)

The Institution of Engineering and Technology is registered as a Charity in England & Wales (no 211014) and Scotland (no SC038698).



**Affiliated and amalgamated schemes:**

Assuring Competence in Engineering Construction (ACE)	<a href="http://www.ecitb.org.uk">www.ecitb.org.uk</a>
Certificate of Competence of Demolition Operatives (CCDO)	<a href="http://www.ndtg.org/card_scheme">http://www.ndtg.org/card_scheme</a>
Construction Industry Scaffolders Record Scheme (CISRS)	<a href="http://www.cisrs.org.uk/">http://www.cisrs.org.uk/</a>
Construction Plant Competence Scheme (CPCS)	<a href="http://www.cskills.org/cpcs">http://www.cskills.org/cpcs</a>
Construction Skills Register (CSR)	<a href="http://www.cefni.co.uk/">http://www.cefni.co.uk/</a>
Electrotechnical Certification Scheme (ECS)	<a href="http://www.jib.org.uk/ecs1.htm">http://www.jib.org.uk/ecs1.htm</a> <a href="http://www.ecscard.org.uk/">http://www.ecscard.org.uk/</a>
Energy and Utility Skills Register (EUSR)	<a href="http://www.eusr.co.uk/">http://www.eusr.co.uk/</a>
Join Industry Board for Plumbing and Mechanical Services (JIB-PMES)	<a href="http://www.jib-pmes.org.uk/">http://www.jib-pmes.org.uk/</a>
Engineering Services Skillcard (SKILLcard)	<a href="http://www.skillcard.org.uk/">http://www.skillcard.org.uk/</a>
Scottish and Northern Irish Joint Industry Board (SNIJIB)	<a href="http://www.snijib.org/">http://www.snijib.org/</a>

professional organisations will be assessed against the competency criteria of their respective professional organisation with the non site based criteria being dropped.

This is being introduced to make the scheme simpler.

There is a briefing session planned that is aimed at members of the professional organisations to talk about the changes to the scheme on the 25th March 2010 at The Royal Institute of British Architects (RIBA) HQ in London.

Persons interested in attending should do so via email ([feedback@cscs.gb.com](mailto:feedback@cscs.gb.com)).

**Further information**

■ More information on the CSCS is available from the following site: [www.cscs.uk.com](http://www.cscs.uk.com)

■ A list of approved institutions is available from the following link: <http://www.cscs.uk.com/professions>

■ More information on ConstructionSkills is available from: <http://www.cskills.org/>.

■ Health and safety test preparation material is available from the following site: <http://www.healthandsafetytest.co.uk/>

Construction Confederation <a href="http://www.thecc.org.uk">www.thecc.org.uk</a>
Federation of Master Builders <a href="http://www.fmb.org.uk">www.fmb.org.uk</a>
GMB Union <a href="http://www.gmb.org.uk">www.gmb.org.uk</a>
National Specialist Contractors Council <a href="http://www.nscs.bbsnet.co.uk">www.nscs.bbsnet.co.uk</a>
T&G Section of UNITE (Building Crafts Section) <a href="http://www.unitetheunion.com">www.unitetheunion.com</a>
Union of Construction, Allied Trades and Technicians <a href="http://www.ucatt.info">www.ucatt.info</a>





# Types of person and the requirements of the Wiring Regulations **Part 2**

by Jon Elliott



In the last edition of Wiring Matters we looked at the types of person recognised by the Wiring Regulations, the skills sets that they possessed and the differences in their abilities. In this article we will consider particular requirements within BS 7671 where the type of person involved is of some significance.

## **BS EN 61140 Protection against electric shock.**

Common aspects for installa-

tion and equipment requires that:

- *hazardous-live-parts shall not be accessible*
- *accessible conductive parts shall not be hazardous live when there is no fault or under single fault conditions*

BS EN 61140 states that those protective measures providing protection under normal conditions (that is, when no faults exist) provide basic protection

and those protective measures giving protection under single fault conditions provide fault protection (Section 410 refers).

The measures of protection by automatic disconnection of supply, double insulation and reinforced insulation, electrical separation to supply a single item of equipment and extra-low voltage (SELV or PELV) are generally applicable (Regulation 410.3.3).

However, in practice automatic disconnection of supply is the most commonly employed method for electrical installations while double and reinforced insulation are more frequently encountered in items of equipment rather than installations per se. Electrical separation, SELV and PELV are typically only applied to specific parts of an installation.

In any case, BS 7671:2008

Fig: 417 Arm's reach

requires the protective measures mentioned above to provide for basic and fault protection either separately or, in the case of enhanced protection from a single measure (Regulation 410.3.2 refers).

**Basic protection**

Measures for basic protection such as basic insulation, barriers and enclosures are generally applicable and as such may be employed in installations or parts thereof, which are accessible to ordinary persons - that is, which are accessible to anybody. However, care must be taken in the use

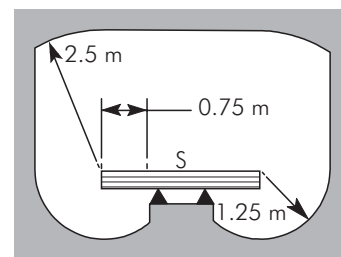
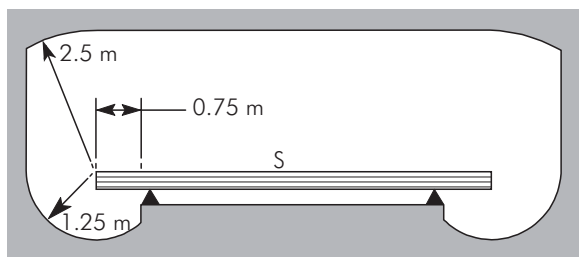

S = surface expected to be occupied by persons

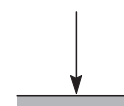
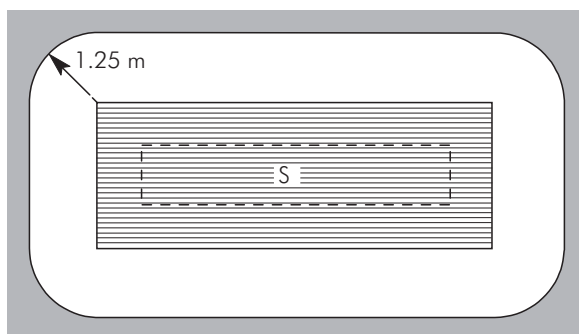

limit of arm's reach

The values refer to bare hands without any assistance, e.g. from tools or a ladder.

The following protective methods are recognised in BS 7671:

Basic protection	Fault protection
Basic insulation	Protective earthing
Barriers	Protective equipotential bonding
Enclosures	Automatic disconnection in the event of a fault
Obstacles	Automatic disconnection of supply for the primary circuit and connection of exposed-conductive-parts of the secondary circuit connected to the protective conductor of the primary circuit of the source
Placing out of reach	Supplementary insulation
<b>Reinforced insulation</b>	
	Simple separation
	Non-conducting location
	Earth-free local equipotential bonding

of the measures of obstacles and placing out of reach to prevent access of persons (or indeed livestock) with live parts as both measures may be deliberately or in some cases unintentionally circumvented (Regulation 417.2). Because of this, the use of these two methods is restricted to installations, or parts thereof, which can only be accessed by skilled persons or instructed persons under the supervision of skilled persons (Regulations 410.3.5 and 417.1)

To be effective an obstacle (as defined) should prevent unintentional bodily approach to, and contact with, live parts during the normal operation and use of the equipment in question (Regulation 417.2.1). However an obstacle may be readily removable without the use of a key or tool (Regulation 417.2.2).

Placing out of reach requires a designer to ensure that simultaneously accessible parts at different potentials are not placed within arm's reach (Regulation 417.3.1). Arm's reach is considered to span 1.25 m horizontally and 2.5 m vertically as shown in

figure 417 of BS 7671:2008 which is reproduced above. However this does not take into account the use of ladders or work involving long conducting objects and tools and so the use of such within areas where basic protection is provided by placing live parts out of reach should be the subject of serious consideration.

In the case of items of street furniture, basic protection may only be provided by placing out of reach where the item in question is situated more than 1.5 m from a low voltage overhead line unless the maintenance of said equipment is only to be carried out by skilled persons (Regulation 559.10.1).

Wherever the use of either obstacles or placing out of reach is employed it is necessary to provide the required equipment, instruction and training to allow the skilled persons and the instructed persons under their supervision to be able to work safely. As such, those parts of an installation where such measures are employed should be clearly identified by the posting of notices and measures, such as, securing with locks and permit-to-work

systems should be put in place to control access and work activities undertaken therein.

When a designer is considering the use of obstacles or placing out of reach to provide basic protection, it is strongly recommended that careful consideration be given to the statutory requirements relating to:

- system, work activities and work equipment (Regulation 4 of the Electricity at Work Regulations 1989 - EWR)
- insulation, protection and placing of conductors (Regulation 7 of EWR)
- work on or near live conductors (Regulation 14 of EWR)
- Earthing or other suitable precautions (Regulation 8 of EWR)
- working space, access and lighting (Regulation 15 of EWR), and
- persons to be competent to prevent danger and injury (Regulation 16 of EWR)

Considerable guidance in support of these regulations can be found in Memorandum of guidance on the Electricity at Work Regulations 1989 (HSR25) published by the Health and Safety Executive and available as a free download from the HSE website.

### Fault protection

In the case of automatic disconnection of supply (ADS), fault protection is provided through the provision of protective earthing, protective equipotential bonding and automatic disconnection in the event of a fault including, where applicable additional protection (Regulation 411.10).

Additional protection by means of an RCD with a rated residual operating current not exceeding 30 mA and giving an operating time not exceeding 40 ms at a residual current of 5 I<sub>Δn</sub> should be provided

for socket-outlets not exceeding a rating of 20 A intended for general usage by ordinary persons, and for mobile equipment of rating less than 32 A that will be used outdoors (411.3.3). A relaxation of this requirement is however permitted for socket-outlets which will be used, in for example, those industrial and commercial installations where work activities are under the effective control of skilled or instructed persons and the work activities taking place do not of themselves make RCD provision essential. This issue will be considered in further detail later in this article.

Where functional extra-low voltage is employed, it is necessary to connect the exposed-conductive-parts of the equipment so supplied to the protective conductor of the primary circuit of the source *in addition* to those protective measures required for ADS (Regulation 411.7.3)

In the case of an accessible enclosure forming part of street furniture it should only be possible to gain access to the live parts within by the use of a key or a tool, unless said enclosure is so located that only skilled or instructed persons have access (Regulation 559.10.3.1). Where isolation and switching operations on street furniture supplied from a TN supply are intended only to be carried out by, at the least, instructed persons and where the necessary precautions have been taken to prevent said equipment from being re-energised prematurely in a manner that could give rise to danger, it is acceptable for switching on-load and isolation to be achieved by removal of the distributor's fuse therein.

### Cables concealed in walls

It has long been a requirement of the Wiring Regulations that where cables are concealed in walls or partitions at a depth of less than 50 mm from the

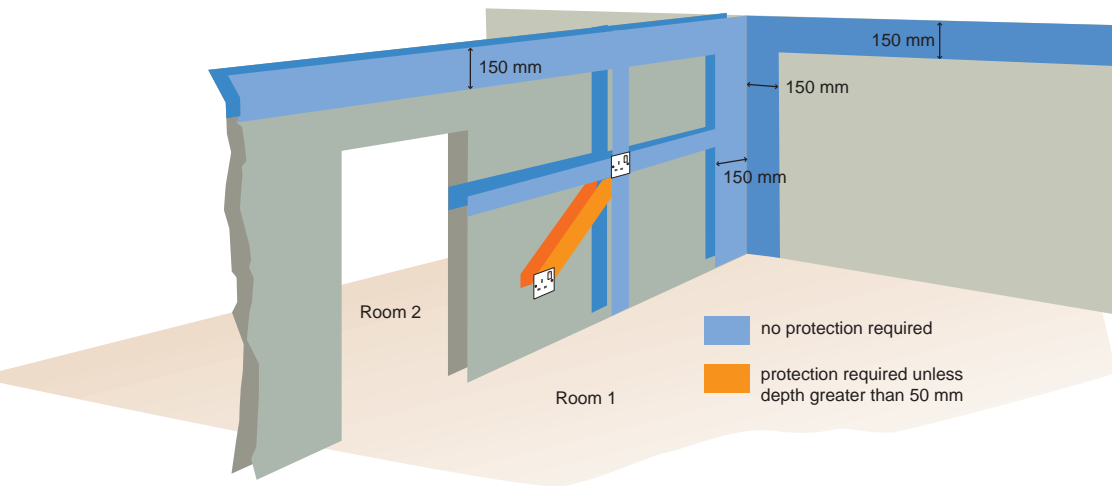

surface that they either:

- incorporate an earthed metallic covering such as armouring or sheath, or
- be enclosed in an earthed conduit, trunking or duct, or
- be otherwise protected against penetration by nails, screws and the like by the addition of mechanical protection, or
- be installed in the safe zones as shown in the diagram below (Regulation 522.6.6)

In the case of an installation not under the supervision of a skilled or instructed person the 17th Edition has introduced a requirement that an RCD having a rated residual operating current not exceeding 30 mA and meeting the conditions contained in Regulation 415.1.1 must be installed to provide additional protection where an insulated and sheathed or similar type cable is run in the safe zones without any other form of mechanical protection. A similar requirement has also been introduced for situations where such cables are installed in partitions formed in part from metallic components (Regulation 522.6.8 (v)). So, additional protection by means of an RCD as described above would be required for domestic premises. Additional protection may also be required in some commercial or industrial instal-

lations irrespective of whether they are under the supervision of a skilled or instructed person as Regulation 6 of the EAWR 1989 requires electrical equipment to be of such construction or otherwise suitably protected to prevent danger. This can be the provision of RCDs where the environment of use increases the risk of sustaining an electric shock. Wet working environments, such as those in kitchens, are an example of where this would apply.

#### RCDs and circuit-breakers

RCDs powered from an independent auxiliary source and which do not operate automatically in the event of a failure of the auxiliary source may only be used in an installation if either fault protection is still maintained in the event of loss of the auxiliary source or the installation is under the control of a skilled or instructed person and regularly inspected/tested by a person competent in such work (Regulation 531.2.6). Where an RCD can be accessed and operated by one other than a skilled or instructed person (that is, therefore, an ordinary person) it should be of a type where it is not possible to effect any changes or adjustments to the settings for its operational sensitivity or time delay thereof without the use of a key or tool (Regulation 531.2.10). A similar requirement exists relating to

the modification or adjustment of the overcurrent settings of circuit-breakers (Regulation 533.1.2).

#### Isolators, switchgear and controlgear

Regulation 537.1.2 states that the neutral conductor in a TN-S or TN-C-S system need not be isolated and switched. Where a link is inserted in the neutral conductor, it should not be possible to remove the link without the use of a key or tool and/or it should be placed so that is accessible to skilled persons only (Regulation 537.2.2.4). Any main switch intended to be operated by ordinary persons should disconnect both poles of a single-phase supply (Regulation 537.1.4).

Where a single-phase installation having a supply rated at 100 A or less such as the majority of domestic premises is to be left under the control of ordinary persons, the switchgear and controlgear therein should either comply with the requirements given in BS EN 60439-3 *Particular requirements for low-voltage switchgear and controlgear assemblies intended to be installed in places where unskilled persons have access to their use. Distribution boards.* In the case of a consumer unit, the constituent component parts including the protective

devices should comply with the relevant parts of BS EN 60439-3.

#### Insulation monitoring devices

It is a requirement in installations supplied from an IT system that an Insulation monitoring device (IMD) is installed to continuously monitor the insulation resistance of the complete system including and extending beyond the secondary side of the source of supply (Regulation 538.1.1) to indicate when a first fault occurs between a live part and an exposed-conductive-part or between a live part and Earth (Regulation 411.6.3.1). Where such devices are located in positions accessible by ordinary persons - that is persons who are neither skilled nor instructed - the IMD should be so designed or installed such that the use of a key, tool or password is required before changes can be made to operational settings (Regulation 538.1.3).

#### Storage batteries and safety sources

Storage batteries are commonplace in most industrial and commercial installations either to provide a back-up supply as is the case with fire and security alarm systems, emergency lighting and uninterruptible power supply (UPS) systems or to provide a source of supply independent of that derived from the public distribution network to supply, for example, compressors designed to run standby generation up to speed in the event of supply failure. Batteries may present a shock risk and flammable gases may be released in normal use. In both cases ordinary persons may not be aware of the risks that may exist. As a result batteries forming part of an installation should be so placed that they are only accessible to skilled or instructed persons (Regulation 551.8.1).

A safety source for a safety service, whatever its nature (Regulation 560.6.2), and



The protective bonding conductors associated with the electrical installation in this location **MUST NOT BE CONNECTED TO EARTH.**

Equipment having exposed-conductive-parts connected to earth must not brought into this location.

any associated switchgear and controlgear (Regulation 560.7.5) should also be in a location only accessible to skilled or instructed persons.

#### Fault protective measures subject to supervisory restrictions

Moving away from protection by ADS, Regulation 410.3.6 permits non-conducting location, earth-free local equipotential bonding and electrical separation for the supply to more than one item of current using equipment to provide fault protection but only where the installation, or more realistically, that part thereof protected by such measures, remains under the supervision and effective control of skilled or instructed persons (Section 418).

The protective measure of non-conducting location is very seldom used within the United Kingdom but a summary of the requirements relating to its use is given below:

- It should not be possible under normal operating conditions for persons to be able to make simultaneous contact between
  - two exposed-conductive-parts, or
  - an exposed-conductive part and an extraneous-conductive part

where such parts can be at different potentials (Regulation 418.1.2)

- no protective conductors should extend into the location so protected (Regulation 418.1.3)
- exposed and extraneous-conductive parts are deemed to be adequately separated through
  - the relative spacing between them being not less than 2.5 m or 1.25 m if placed beyond arm's reach
  - the placing of obstacles between exposed and extraneous-conductive parts
  - the insulation, whether in-

herent or applied, of extraneous-conductive parts (non-conducting location 418.4)

- the resistance of insulating walls and floors within the location when tested in accordance with the requirements of Regulation 612.5.1 should not exceed the values given in Appendix 13 appropriate to the particular test method employed (non-conducting location - Regulation 418.1.5)

All of the above requirements need to be present for the measure to be effective. This is why it is so important that effective control and supervision of the location so protected is maintained. If inadequately supervised, the measure can be rendered ineffective and therefore potentially dangerous by the introduction of class I items of mobile equipment or indeed extraneous-conductive parts. Moreover, persons placed in control of a location so protected will need to ensure that excessive humidity does not reduce the insulation resistance of the floors and walls of the location beyond acceptable levels (Regulation 418.1.6).

The responsible person must also ensure that no potentials which might give rise to danger are allowed to appear beyond the location from within (Regulation 418.1.7)

Protection by earth-free local equipotential bonding is a fault protection measure which can only realistically be applied to a particular area or location within the greater installation. In order for this protective measure to be effective all exposed and extraneous-conductive parts within the location must be electrically separate from earth or other potentials being introduced from outside (Regulation 418.2.3) and, if simultaneously accessible, be connected together by local protective bonding conduc-

tors (Regulation 418.2.2). The accessible floor surface within such a location may be constructed of non-conducting materials or from a conductive floor connected to the local earth-free bonding within the location and wholly insulated from Earth.

A particular risk of shock can exist at the point where persons pass into the earth-free protected area from the greater, earthed, installation and so effective supervision at this point must be maintained to ensure that precautions such as insulating mats or floor panels at the point of transition are not removed and remain in a serviceable condition (Regulation 418.2.4). Other potential risks

arising from persons unfamiliar with the method of protection being employed are that during the course of alterations, additions, maintenance or repair work a connection to earth is introduced into the location or that portable and/or handheld tools or equipment having exposed conductive parts are used in the location whilst connected to the earthed supply within the "normal" installation. In the hope of preventing this from occurring it is a requirement that the warning notice reproduced above (Regulation 514.13.2) is posted at any and all points of entry to the location protected by earth-free local equipotential bonding (Regulation 418.2.5).

The use of a supply from a TN system can introduce an earth into the location via the earthed neutral conductor. As a result the supply to a location where earth-free local equipotential bonding is used as a protective measure is most likely to be taken from a source employing electrical separation.

Electrical separation for the supply to more than one item of equipment is a protective measure so arranged that a single fault or first fault should not present a risk of electric shock occurring. However as the presence of such a fault is unlikely to be detected in normal use a potentially dangerous situation could arise if further faults were to occur. As a result it is a requirement for the separated circuit to be so arranged as to minimise the risk of damage or insulation failure occurring (Regulation 418.3.3).

All exposed-conductive parts associated with the separated circuit are required to be connected together by non-earthed, insulated protective bonding conductors and no connection should be made from the exposed-conductive parts so bonded to the protective conductor, exposed-conductive parts of other circuits, or any extraneous-conductive parts within the location (Regulation 418.3.4) and the protective conductor contact of socket-outlets are to be connected to the bonded exposed-conductive parts (Regulation 418.3.5). Again it can be seen that effective supervision must be

provided to ensure that the above requirements are not deliberately or accidentally defeated rendering the method of protection ineffective.

#### Special installations and locations

To be included in Part 7 of BS 7671 a location or type of installation should present an increased risk of shock to persons (or livestock) either by its nature or from how it is used. To illustrate this, a construction site is a harsh environment for an electrical installation, and the likelihood of damage occurring to wiring systems and equipment is, relatively speaking, high. As a result, special measures are required to ensure that the installation is sufficiently robust. In the case of a swimming pool the increased risk of shock is as a direct result of factors such as the lack of dry (and therefore insulating) footwear and clothing and the significantly reduced resistance of skin when wet. A number of installations or locations covered by Part 7 are subject to specific requirements related to the types of person recognised by BS 7671.

Where extra-low voltage transformers are employed in an electrical installation forming part of an exhibition, show or stand falling within the scope of Section 711, the transformers should be so placed that they are not within arm's reach of members of the public (that is, ordinary persons as defined) and such that they can be accessed to facilitate testing and maintenance by skilled persons competent in such work (Regulation 711.55.6).

Some types of mobile and transportable unit are capable of being connected to a wide range of potential supplies. However hazardous situations may arise from loss of continuity of the connection to the source of earth, an open circuit on a PEN conductor (as defined) resulting in a diverted neutral current or if the unit contains much electronic equipment a potentially harmful functional current being present on earthed metal-work. As a result, regulation 717.411.4 states that:

- a suitably skilled or instructed person has confirmed the suitability of the means of earthing prior to connection, and that
- a mobile or transportable unit may only be connected to a supply derived from a TN-C-S system where the unit remains under continuous supervision by a skilled or instructed person whilst in use, it being their responsibility to confirm the effectiveness of the means of earthing for the unit whilst it is in use.

Where safety isolating transformers are employed in a temporary installation within a fairground, amusement park or circus they should be mounted out of arm's reach or failing that, installed such that they are only accessible to skilled or instructed persons. Moreover, there should be adequate means of access to permit inspection, testing and maintenance (Regulation 740.55.5) and with the exception of those items intended for operation by ordinary persons, all switchgear and controlgear

should be placed inside enclosures which can only be opened by the use of a key or a tool (Regulation 740.51).

#### Inspection and testing

In the case of most types electrical installation there is no statutory requirement to carry out inspection and testing periodically. It is, however, a commonly adopted practice seen as a means of meeting the maintenance obligations given in, for example, the Electricity at Work Regulations 1989 (Regulation 4) and the Housing Act 1985 (Section 11). BS 7671 is in the most part concerned with the design, installation, and initial inspection and testing of new installations but Chapter 62 contains a number of requirements relating to periodic inspection and testing. Regulation 622.2 states that periodic inspection and testing is not required where an installation is under an effective management system operated by skilled persons covering its maintenance. However, and as has been mentioned previously, the persons responsible may be held accountable in the event of an incident occurring. As such, appropriate records must be kept of the maintenance activities undertaken.

#### Useful reading

Guidance Note 2 – Isolation and switching. Published by the IET  
 Guidance Note 5 – Protection against shock. Published by the IET  
 HSR 25 – Memorandum of guidance on the Electricity at Work Regulations 1989. Published by the HSE  
 HSG 85 – Electricity at work.

### Megger opportunity to end the recession



The "Business in a Box" is a new and innovative product line which has been specifically developed to make it as easy as possible for electrical contractors to generate extra income. Find out more by attending a MeggerTalks! event in your area.

To book your place call Rosa on 01304 502 236 or visit <http://www.megger.com/uk/events>

[www.megger.com](http://www.megger.com)

### NEW 17TH EDITION SOFTWARE HAS UNIQUE FEATURES

Seaward has expanded its PowerPlus PC software for the fast and efficient production of 17th edition electrical test certification.

The new software allows data from different testers to be merged onto one certificate and enables the cloning of test certificates for similar electrical installations.

By enhancing the transfer of test data between the PowerPlus 1557 tester and main PC records, the new software considerably improves the working efficiency of contractors.



Seaward Electronic Ltd. Bracken Hill, South West Industrial Estate, Peterlee, County Durham, SR8 2SW Tel. (0191) 586 3511 Fax. (0191) 586 0227 E. [sales@seaward.co.uk](mailto:sales@seaward.co.uk)

[www.seaward.co.uk](http://www.seaward.co.uk)



### Neweys Online - order up until 8pm for next day delivery or to collect in branch

Neweys Online Click & Collect allows you to order your electrical goods on [www.neweysonline.co.uk](http://www.neweysonline.co.uk) and then collect them from any of our 150 branches the next day. Simply place your order online by 8pm and we'll have your order ready and waiting for you in your chosen branch from 8am the following morning.

[www.neweysonline.co.uk](http://www.neweysonline.co.uk)



### FREE Estimating Software & Catalogue DVD

Electrika is supported by the UK's leading brands to bring you:

- 140,000 updated Trade Prices
- 1000's PDF Catalogues & Technical Docs
- Professional quality Estimating package
- Built-in Ordering & Job Costing
- Add your own Specials
- Create your own Local Databases
- Regular price updates

Visit [www.electrika.com](http://www.electrika.com) to register for your Free DVD

Electrika Ltd

T: 0161 945 5124 E: [info@electrika.com](mailto:info@electrika.com)

[www.electrika.com](http://www.electrika.com)

### Handheld Electronic Label Printer

Brother's P-touch range of durable handheld electronic label printers are perfect for electrical installers who need to mark wiring and tools clearly and effectively. Brother's patented TZ tapes create durable labels that are scuff, fade, water, temperature and chemical resistant. The label printers are designed to withstand tough on-site conditions and their compact design make them easy to store and transport.

Brother T: 0844 499 9444



**brother**  
at your side

[www.brother.co.uk/labelling](http://www.brother.co.uk/labelling)

### On-Site Guide

The On-Site Guide is intended to enable the competent electrician to deal with small installations (up to 100 A, 3-phase). It includes simple circuit calculations and provides essential information in a convenient, easy-to-use form, avoiding the need for detailed calculations. Buy your copy at [www.theiet.org/osg](http://www.theiet.org/osg)

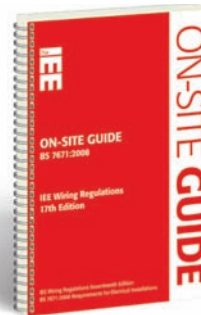

Institution of Engineering and Technology  
Michael Faraday House  
Six Hills Way, Stevenage. SG1 2AY  
T: +44 (0)1438 313311

[www.theiet.org/osg](http://www.theiet.org/osg)



### CREDIT CRUNCH TAKING EFFECT?

For a limited period of time, NAPIT is offering you the opportunity to transfer your electrical membership to NAPIT for \*FREE and receive 18 months for the price of 12!\*

This offer is only valid until 7th June 2010, so call NAPIT on: 0870 444 1392 or alternatively email: [info@napit.org.uk](mailto:info@napit.org.uk)

\* Conditions apply

NAPIT  
4th Floor, Mill 3, Pleasley Vale Business Park  
Mansfield, Nottinghamshire. NG19 8RL

[www.napit.org.uk](http://www.napit.org.uk)

### In-Company electrical training

The IET runs in-company electrical training courses which are carefully tailored to best suit your company's requirements. Reduce staff time away from the workplace and eliminate travel and accommodation costs by having courses run on your premises.

Contact us to discuss your requirements on 01438 767289 or email [coursesreg@theiet.org](mailto:coursesreg@theiet.org)

The IET  
T: 01438 767289  
E: [coursesreg@theiet.org](mailto:coursesreg@theiet.org)



[www.theiet.org/courses](http://www.theiet.org/courses)

The Institution prepares regulations for the safety of electrical installations for buildings, the IEE Wiring Regulations (BS 7671), which has now become the standard for the UK and many other countries. It has also prepared the Code of Practice for Installation of Electrical and Electronic Equipment In Ships (BS 8450) and recommends, internationally, the requirements for Mobile and Fixed Offshore Installations. The Institution provides guidance on the application of BS 7671 through publications focused on the various activities from design of the installation through to final test and certification with further guidance for maintenance. This includes a series of eight Guidance Notes, two Codes of Practice and model forms for use in wiring installations.

**BEST SELLER**

## REQUIREMENTS FOR ELECTRICAL INSTALLATIONS

BS 7671:2008  
(IEE Wiring Regulations, 17th Edition)

The Wiring Regulations are the national standard to which all domestic and industrial wiring must conform. Substantial changes have been incorporated in BS 7671:2008 to align with European documents. Essential for all electricians, electrical contractors and their managers, installation designers, and students in further education and professional training.

**Contents:** Scope, Object and Fundamental Principles. Definitions. Assessment of General Characteristics. Protection for Safety. Selection and Erection of Equipment. Special Installations or Locations. Inspection and Testing.

- Paperback 389pp
- 2008
- ISBN 978-0-86341-844-0
- Order book PWR1700B

£75

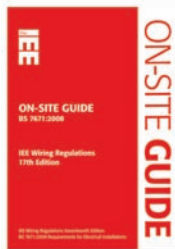
**BEST SELLER**

## ON-SITE GUIDE

BS 7671:2008

The On-Site Guide is intended to enable the competent electrician to deal with small installations (up to 100 A, 3-phase). It provides essential information in a convenient, easy-to-use form, avoiding the need for detailed calculations.

**Contents:** Introduction. The service position. Protection. Earthing and bonding. Isolation and switching. Labelling. Final circuits. Locations containing a bath or shower. Inspection and testing. Guidance on initial testing of installations. Operation of RCDs.

- Paperback 180pp
- 2008
- ISBN 978-0-86341-854-9
- Order book PWGO170B

£22

**BEST SELLER**

## ELECTRICAL INSTALLATION DESIGN GUIDE

Calculations for Electricians and Designers

This book provides step-by-step guidance on the design of electrical installations, from domestic installation final circuit design to fault level calculations for LV/large LV systems.

Apprentices and trainees will find it very helpful in carrying out the calculations necessary for a basic installation. It has also been prepared to provide a design sequence, calculations and data for a complete design to be carried out. It is intended to include all necessary cable and equipment data to carry out the calculations. Consultants will be able to check the calculations of their design packages.

It includes calculations and necessary reference data not found in the design packages, such as cable conductor and sheath temperatures and allowances for harmonics.

**Contents:** Design sequence. Simple installations and final circuits. Maximum demand and diversity. Selection of cables for current-carrying capacity. Voltage drop. Fault current. Shock protection. Protective conductors. Calculations associated with testing. Impedance of copper and aluminium conductors. Harmonics. Protection against voltage disturbances. Busbar trunking. Appendices. Index.

- Paperback 186pp
- 2008
- ISBN 978-0-86341-550-0
- Order book PWR05030

£22

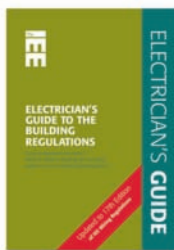
**BEST SELLER**

## ELECTRICIAN'S GUIDE TO THE BUILDING REGULATIONS

Part P, 2nd Edition

Updated to align with the 17th Edition of the IEE Wiring Regulations, it also includes a new chapter on requirements for Scotland.

**Contents:** Legislation. Design, selection and erection of electrical installations. Mains position. Circuit specifications. Special installations, special locations and kitchens. Inspection and testing. Safe working. Maintenance. Three-phase supplies. Other Building Regulations. Identification of conductors. Scottish building standards. Appendices. Index.

- Paperback 234pp
- 2008
- ISBN 978-0-86341-862-4
- Order book PWGP170B

£22

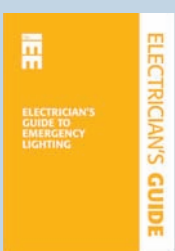
**NEW** NOW AVAILABLE

## ELECTRICIAN'S GUIDE TO EMERGENCY LIGHTING

P Cook

The Electrician's Guide to Emergency Lighting is one of a number of publications prepared by the IET to provide guidance on electrical installations in buildings. This publication is concerned with emergency lighting and in particular emergency escape lighting and must be read in conjunction with the legislation: Approved Document B and the British Standards, in particular BS 5266.

- Paperback c88pp
- 2009
- ISBN 978-0-86341-551-7
- Order book PWR05020

£22

## BEST SELLING WIRING REGULATIONS BOOK SERIES



### ELECTRICAL CRAFT PRINCIPLES:

Volume 1, 5th Edition

**NOW AVAILABLE**

- Paperback 344pp
- 2009
- ISBN 978-0-86341-932-4
- Order book PBNS0330

£25



### ELECTRICAL CRAFT PRINCIPLES:

Volume 2, 5th Edition

**NOW AVAILABLE**

- Paperback 432pp
- 2009
- ISBN 978-0-86341-933-5
- Order book PBNS0340

£25



### GUIDANCE NOTE 1:

Selection & Erection of Equipment, 5th Edition

**NOW AVAILABLE**

This Guidance Note enlarges upon and simplifies relevant requirements of BS 7671:2008. It includes detailed coverage of external influences and factors affecting the installation of cables and equipment. It discusses various types of protective devices in easy-to-read text and includes illustrations in full colour.

- Paperback 216pp
- 2009
- ISBN 978-0-86341-855-6
- Order book PWG1170B

£30



### GUIDANCE NOTE 2:

Isolation & Switching, 5th Edition

**NOW AVAILABLE**

This Guidance Note enlarges upon and simplifies relevant requirements of BS 7671:2008. It includes detailed coverage of mechanical maintenance, emergency switching, functional switching in easy-to-read text. It also includes illustrations in full colour.

- Paperback 74pp
- 2009
- ISBN 978-0-86341-856-3
- Order book PWG2170B

£25



### GUIDANCE NOTE 3:

Inspection & Testing, 5th Edition

**NOW AVAILABLE**

Suitable for the City & Guilds 2391 Certificate in Inspection, Testing and Certification, this Guidance Note is concerned principally with Inspection and Testing. It has been updated to align with the IEE Wiring Regulations 17th Edition (BS 7671:2008). It includes detailed coverage of initial verification, periodic inspection and test instruments.

- Paperback 128pp
- 2008
- ISBN 978-0-86341-857-0
- Order book PWG3170B

£25



### GUIDANCE NOTE 4:

Protection Against Fire, 5th Edition

**NOW AVAILABLE**

This Guidance Note enlarges upon and simplifies relevant requirements of BS 7671:2008. It includes detailed coverage of thermal effects, locations with increased risk, cable selection and safety service in easy-to-read text. It also includes full-colour illustrations.

- Paperback 104pp
- 2009
- ISBN 978-0-86341-858-7
- Order book PWG4170B

£25



### GUIDANCE NOTE 5:

Protection Against Electric Shock, 5th Edition

**NOW AVAILABLE**

This Guidance Note enlarges upon and simplifies relevant requirements of BS 7671:2008. It includes detailed coverage of the protective measures against electric shock. It also includes full-colour illustrations.

- Paperback 115pp
- 2009
- ISBN 978-0-86341-859-4
- Order book PWG5170B

£25



### GUIDANCE NOTE 6:

Protection Against Overcurrent, 5th Edition

**NOW AVAILABLE**

This Guidance Note enlarges upon and simplifies relevant requirements of BS 7671:2008. It includes guidance on protection of conductors in parallel against overcurrent and includes an overview of the new appendix 4 of BS 7671:2008.

- Paperback 113pp
- 2009
- ISBN 978-0-86341-860-0
- Order book PWG6170B

£25

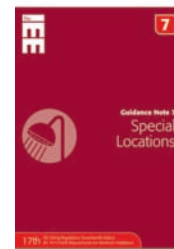

### GUIDANCE NOTE 7:

Special Locations, 3rd Edition

**NOW AVAILABLE**

This Guidance Note enlarges upon and simplifies relevant requirements of BS 7671:2008. It includes detailed coverage of new special locations covered in the IEE Wiring Regulations 17th Edition in easy-to-read text. It also includes full colour illustrations.

- Paperback 142pp
- 2009
- ISBN 978-0-86341-861-7
- Order book PWG7170B

£25



### GUIDANCE NOTE 8:

Earthing & Bonding, 1st Edition

This Guidance Note is principally concerned with the electrical installation aspects of earthing and bonding together with automatic disconnection, which forms the principal protective measure against indirect contact electric shock.

- Paperback 168pp
- 2007
- ISBN 978-0-86341-616-3
- Order book PWRG0241

£25



Electrical excellence

# Calling young professionals.

**Do you use the Wiring Regulations or other Standards?  
Why not help shape the future of international  
standardization and conformity in the field of  
electrotechnical work?**

The IEC is organizing a young professionals' international workshop in Seattle, USA 10th October 2010 and are looking for three young, UK engineers to be the new faces in the field of electricity and electronics standardization.

This is a fantastic opportunity for electrotechnical engineers, managers and technicians, with some experience of standardization, to represent the UK, to attend workshops on standardization, to observe a relevant technical committee where experts develop standards and to visit a local industry.

Three nights' accommodation and return flights sponsored by the IET and the BSI.

Join professionals from all over the world and make your voice heard.  
For more information visit

[www.theiet.org/technical](http://www.theiet.org/technical)

Sponsored by:



The Institution of Engineering and Technology is registered as a Charity in England & Wales (no 211014) and Scotland (no SC038698).



The Institution of Engineering and Technology (IET) is one of the world's leading professional societies for the engineering and technology community with over 150,000 members.

## Electrical Engineer

£40k – Stevenage, Hertfordshire

**An excellent opportunity to be at the forefront of technical standards (BS 7671) in the UK.**

Are you an enthusiastic electrical engineer looking for a new challenge, possibly from an electrical contracting/consultancy background? Drawing on your valuable skills and experience you could be offering guidance and help on our behalf.

You will deal with a wide range of technical queries from our members, industry and the public, via telephone, email, or in writing. Additionally you will act as secretary and manager to various committees and panels, organising meetings, preparing agendas, taking and creating minutes and distributing papers.

Incorporated Engineer level or above, you will be IT literate with a good knowledge of BS 7671 (IEE Wiring Regulations) and have excellent written and verbal communication skills. Sound technical ability will be needed to draft technical papers and give guidance and interpretation.

Benefits include free meals in our staff restaurant and numerous discounts on local products and services and private medical insurance.

With an excellent benefits package we are committed to the personal and professional development of all our staff, encouraging initiative, ownership and confident performance. Our modern offices near Stevenage station are just 25 minutes from Kings Cross and 35 minutes from Cambridge. Our prestigious London office, Savoy Place, overlooks the Thames and is 5 minutes from Covent Garden.

*Please forward your CV to [opportunities@theiet.org](mailto:opportunities@theiet.org)*

**Closing date: 26th March 2010.**

**The Institution of  
Engineering & Technology,  
Michael Faraday House,  
Six Hills Way, Stevenage,  
Herts SG1 2AY**

Visit: [www.theiet.org](http://www.theiet.org)



# Testing of Multipole RCDs

by Mark Coles

The IET's technical helpline has taken a number of calls of late asking how three- and four-pole RCDs operate and how they are to be physically tested. This article looks to answer these and related questions.

The requirements of BS 7671:2008 for testing of residual current devices have been covered a number of times in previous issues of *Wiring Matters* (see the Further Information section at the end of this article on how to obtain back issues), therefore, this information will not be repeated.

Residual current devices BS 7671:2008 carries the following definitions:

**Residual current device (RCD)**

A mechanical switching device or association of devices intended to cause the opening of

the contacts when the residual current attains a given value under specified conditions.

**Residual current.**

Algebraic sum of the currents in the live conductors of a circuit at a point in the electrical installation.

An RCD is a protective device used to automatically disconnect the electrical supply to a part of the electrical installation when an imbalance is detected between live conductors. Note that the term "live conductors" means a conductor or conductive part intended to be energised in normal use, including a neutral conductor but, by convention, not a PEN conductor.

RCD is the generic term for a device that operates when the residual current in the circuit reaches a predetermined

Thanks to MK for the images



**Fig 1 - Split load board with RCCB protecting a number of circuits**

value. The RCD is, therefore, the main component in an RCCB or one of the functions of an RCBO:

**RCCB** - Residual current circuit-breaker - an example is a main switch in a consumer unit protecting the circuits of a number of circuit-breakers in a split-load board.

**RCBO** - Residual current operated circuit-breaker with integral overcurrent protection is an RCD and (miniature) circuit-breaker combined

If a line-to-earth fault develops or current flows in the protective conductor, some of the line conductor current will not return to the source of supply through the neutral conductor. When this residual current reaches a preset limit (the residual operating current -  $I_{\Delta n}$ ), the RCD detects this imbalance, operates and disconnects the circuit from the supply.

#### Single-phase devices

In the case of a single-phase circuit, the RCD will be two-pole and the device will monitor the

difference in currents between the line and neutral conductors. The monitoring or sensing component is usually a coil or toroid. In a healthy circuit, where there is no earth fault current or protective conductor current, the sum of the currents in the line and neutral conductors is zero. Note that faults between line and neutral conductors (short-circuit) are not detected by RCDs, these faults are detected by fuses, circuit-breakers or the overcurrent protection stage of an RCBO.

#### Test Circuit

A test circuit is always incorporated in the RCD. Operation of the test button connects a resistive load between the line conductor on the load side of the RCD and the supply neutral. The test circuit is designed to pass a current, in excess of the tripping current of the RCD, to simulate an out-of-balance condition. Operation of the test button checks the electromechanical integrity of the RCD only.

Regulation 514.12.2 of BS 7671:2008 requires that on all installations where RCDs are



**Fig 2 - RCCB**

present, a notice shall be fixed in a prominent position at or near the origin of the installation, instructing the user to check the function of the RCD by pressing the test button every three-months and to observe that the RCD trips instantly.

It is important to note that the RCD should still be verified by regular periodic inspection, the testing requirements for which, are given in Regulation 621.2.

#### Multipole devices

Where RCD protection is required on three-phase installations, two configurations are possible, i.e. three-pole and four-pole devices. Three-pole devices are intended to be installed on parts of the installation where three-lines are used to supply an item of equipment without a neutral connection; an example of this would be a three-phase induction motor.

Four pole devices are intended to supply an item of equipment that requires a neutral connection.

The operation of multipole devices is similar to that of

two-pole devices; current flow is monitored and, where an imbalance of sufficient magnitude is detected, the device will operate. Where the device is three-pole, all three poles are monitored simultaneously. For four-pole devices, all four poles are monitored

Regulation 531.2.2 of BS 7671:2008 requires that the magnetic circuit of the transformer of an RCD encloses all the live conductors of the protected circuit. The associated protective conductor is to remain outside the magnetic circuit.

Multipole RCDs should not be used to protect entire installations as Section 314 of BS 7671:2008 *Division of installation* requires that every installation shall be divided into circuits, as necessary, to:

- avoid hazards and minimize inconvenience in the event of a fault
- facilitate safe inspection, testing and maintenance
- take account of danger that may arise from the failure of a single circuit such as a lighting circuit
- reduce the possibility of unwanted tripping of RCDs due to excessive protective conductor currents produced

#### Testing

When testing RCDs, probes or clips from the test instrument are attached to the relevant point of the installation to simulate a fault condition. The connections made are dependent on the type of test instrument used as some instruments have two test leads, whilst others have three. Generally, RCD testers with three leads are those that require a connection to neutral whilst two-lead test instruments are simply connected between the line and earthing terminal. Two-lead test instruments will be considered only in this article.





When testing two-pole devices, one test probe is attached to the load side of the line pole, the other to the earthing terminal or associated CPC; when the test is initiated, the device should operate in the required time.

When testing multipole devices, one test probe is attached to the load side of line L1 pole, the other to the earthing terminal or associated CPC; when the test is initiated, the device should operate in the required time.

#### Should a multipole RCD be tested on each line or pole?

As each live conductor of the RCD is incorporated in the magnetic sensing circuit it is not necessary to perform the test for poles L2 and L3. However, if there is any doubt in the authenticity of the device in question - in terms of a fake or counterfeit device - the advice would be to repeat the test for poles L2 and L3. It goes without saying that such important devices, designed to protect life and property, should be obtained from trusted sources and made by reputable manufacturers.

If a decision is made to test the RCD on all three lines, there should be little or no discernable difference in

operating times as each pole is incorporated in the magnetic sensing circuit. If, for example, the test performed on one pole did not meet the required disconnection time, yet, tests on the other two poles were satisfactory, the device should be considered faulty and replaced.

#### Where in the circuit should the RCD be tested?

Whether the RCD in question protects a number of circuits, e.g. on a split load board, or an RCBO is used to protect a single circuit, or an RCD is installed nearer to the item of equipment it is protecting, the tests can be carried out immediately on the load side of the device. Often, it is suggested that an RCD protected circuit should be tested at the extremity, i.e. at the same point at which a  $Z_s$  measurement is taken and that result being the highest on that circuit which is recorded.

There is little to be gained in testing the RCD from the extremity of the circuit it is protecting; for two reasons. Firstly, the test is required to prove that the RCD operates correctly. As the circuit in question will meet all other requirements of the Regulations, i.e. earth fault loop impedance and volt-drop, a long run will

add little to the operating time of the device. Remember that a 30 mA device providing additional protection should operate within 40 ms when tested at  $5I_{\Delta n}$  (Regulation 415.1 of BS 7671:2008) and that the maximum earth fault loop impedance should not exceed  $1667 \Omega$  (Table 41.5 of BS 7671:2008). Secondly, a second operative will be needed to reset the device after each test otherwise the tester may face a long walk returning to the device location. The RCD should be tested with the load switched off or the load disconnected from the circuit. The reason being that if the connected load has a standing leakage or

has a designed protective conductor current, it will be added to the test current thus giving a false test result.

#### Legal requirements

And finally, just a quick line or two about the legal requirements and competency. When testing RCDs, it is necessary to work on live equipment. The Electricity at Work Regulations 1989 (EWR) recognises that some work, such as fault finding and testing, may require electrical equipment to remain energised during the work. In these cases, if there may be danger from live conductors, regulation 14 of the EWR makes particular requirements. Regulation 16 - dealing with competency - also applies, guidance on the EWR is available from HSE, see the Further Information section below.

#### Regulation 16 Persons to be competent to prevent danger and injury

No person shall be engaged in any work activity where technical knowledge or experience is necessary to prevent danger or, where appropriate, injury, unless he possesses such knowledge or experience, or is under such degree of supervision as may be appropriate having regard to the nature of the work.

The object of the regulation

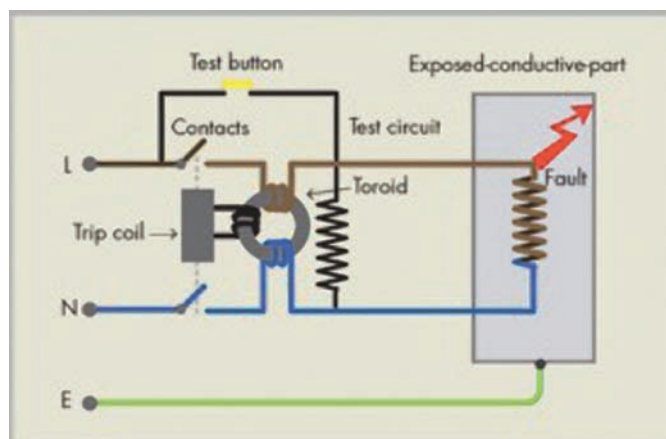

Fig 3 - Schematic diagram of an RCD

is to ensure that persons are not placed at risk due to a inadequacies in training or understanding. The key words prevent danger or, where appropriate, injury are highlighted. The regulations recognise those circumstances where danger is present, i.e. where there is a risk of injury, as for example where work is being done on live equipment using special techniques and under the terms of regulation 14. In these circumstances, persons must possess sufficient technical knowledge, be experienced or be so supervised to be capable of ensuring that injury is prevented.

The scope of 'technical knowledge or experience' may include:

- adequate knowledge of electricity
- adequate experience of electrical work
- adequate understanding of the system to be worked on and practical experience of that class of system
- understanding of the hazards and precautions which need to be taken
- ability to recognise at all times whether it is safe for work to continue.

Workers should be trained and instructed to ensure that they understand the safety procedures which are relevant to their work and should work in accordance with any instructions or rules directed at ensuring safety which have been laid down by their employer or site operator.

Regulation 16 recognises

that in many circumstances persons will require to be supervised to some degree where their technical knowledge or experience is not of itself sufficient to ensure that they can otherwise undertake the work safely. The responsibilities of those undertaking the supervision should be clearly stated to them by those duty holders who allocate the responsibilities for supervision and consideration should be given to stating these



responsibilities in writing. Where the risks involved are low, verbal instructions are likely to be adequate but as the risk or complexity increase there comes a point where the need for written procedures becomes important in order that instructions may be understood and supervised more rigorously. In this context, supervision does not necessarily require continual

attendance at the work site, but the degree of supervision and the manner in which it is exercised is for the duty holders to arrange to ensure that danger or as the case may be, injury, is prevented.

The HSE publication *Safety in electrical testing at work* INDG354 contains guidance on good practice which are not compulsory but may be found helpful in considering what is necessary.

#### Post script

With the introduction of BS 7671:2008, a number of terms were changed as the UK adopted the technical requirements of CENELEC Harmonized Documents. In the adoption process, line conductor replaced phase conductor (not to be confused with live conductor) but we would still refer to three-phase

supplies or three-phase motors.

#### Further information

- BS 7671:2008 Requirements for Electrical Installations, IEE Wiring Regulations, Seventeenth Edition
- Electricity at Work Regulations 1989 - [www.opsi.gov.uk/si/si1989/Uksi\\_19890635\\_en\\_1.htm](http://www.opsi.gov.uk/si/si1989/Uksi_19890635_en_1.htm)
- Memorandum of guidance on the Electricity at Work Regulations 1989 (HSR25) - free download - [www.hse.gov.uk/pubns/books/hsr25.htm](http://www.hse.gov.uk/pubns/books/hsr25.htm)
- Safety in electrical testing at work, HSE publication INDG354
- [www.hse.gov.uk/pubns/indg354.pdf](http://www.hse.gov.uk/pubns/indg354.pdf)
- Guidance Note 3 - Inspection and Testing, 5th Edition, published by the IET [www.theiet.org/publishing/books/wir-reg/inspection-testing-5th-edition.cfm](http://www.theiet.org/publishing/books/wir-reg/inspection-testing-5th-edition.cfm)
- BEAMA are due to publish their updated guide to RCDs [www.beama.org.uk/en/publications/](http://www.beama.org.uk/en/publications/)

Previous issues of Wiring Matters can be downloaded from the IET's website at [www.theiet.org/WM](http://www.theiet.org/WM)  
Back issues relating to the testing of RCDs:  
Summer 2005 - [www.theiet.org/publishing/wiring-regulations/mag/2005/15-insp-test-rcd.cfm?type=pdf](http://www.theiet.org/publishing/wiring-regulations/mag/2005/15-insp-test-rcd.cfm?type=pdf)  
Spring 2008 - [www.theiet.org/publishing/wiring-regulations/mag/2008/26-rcdtest.cfm?type=pdf](http://www.theiet.org/publishing/wiring-regulations/mag/2008/26-rcdtest.cfm?type=pdf)

#### Thanks

Ken Morton at HSE, Paul Sayer at Hager, Malcolm Mullins at MK and BEAMA



Professional Electrician

# ELEX 2010

The Electricians' Exhibition

Sponsored by



Electrical excellence

## Westpoint Arena, Exeter

Thursday 29<sup>th</sup> & Friday 30<sup>th</sup> April 2010

10.00am - 4.00pm



- SEE AND TRY OUT ALL THE LATEST ELECTRICAL PRODUCTS FROM LEADING MANUFACTURERS AND SUPPLIERS
- HUNDREDS OF SHOW DISCOUNTS
- **FREE** INDUSTRY SEMINARS FROM THE ELECTRICAL SAFETY COUNCIL, NICEIC AND IET.
- **FREE** PROFESSIONAL ELECTRICIAN T-SHIRT
- **FREE** BACON ROLL

To register for **FREE** entry, visit

**www.elexshow.info**

 or call

**01923 237799**

$\Omega$   
ohm



Enlightened electricians choose NAPIT

To speak to the industry gurus please call: 0800 954 0438



**Member benefits include:**

- ✓ NO EXTRA CHARGE for electrical commercial & industrial works and periodic reports
- ✓ FREE membership to electrical Trade Association and online forum
- ✓ WORK QUALITY guarantee on notified work
- ✓ FREE legal and technical advice helplines
- ✓ SAVE up to £180 when joining from another scheme provider

[info@napit.org.uk](mailto:info@napit.org.uk) [www.napit.org.uk](http://www.napit.org.uk)